

Possible type of female part "FU"

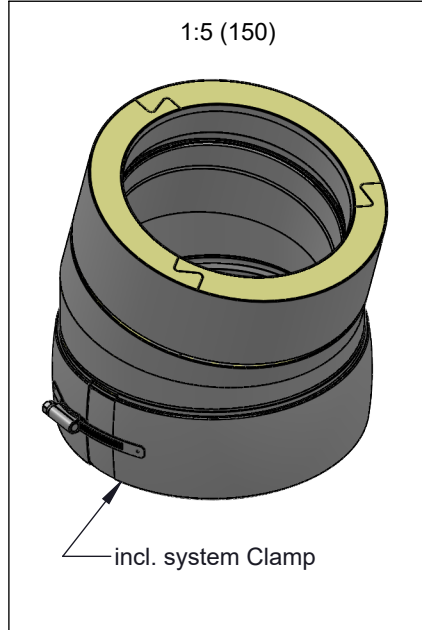
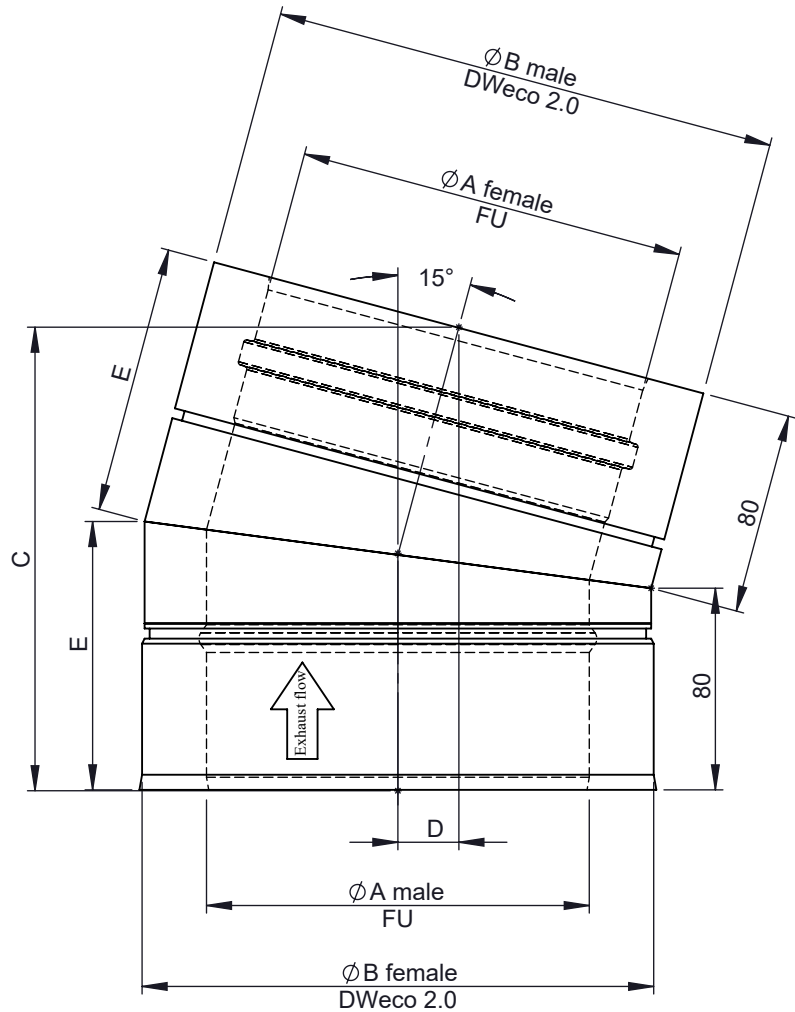
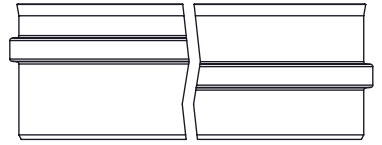

\varnothing	80	100	115	120	130	140	150	160	180	200	225	250	300	350	400	450	500	550	600
A	80	100	115	120	130	140	150	160	180	200	225	250	300	350	400	450	500	550	600
B	130	150	165	170	180	190	200	210	230	250	275	300	350	400	450	500	550	600	650
C	118	121	123	123	125	126	127	129	131	134	137	140	147	153	160	166	173	179	185
D	8		9						10			11	12	13	13	14	15	16	17
E	89	90	91	91	92	93	93	94	95	97	98	100	103	106	110	113	116	120	123
kg	0,73	0,88	0,98	1,02	1,09	1,17	1,24	1,32	1,47	1,63	1,83	2,04	2,47	2,93	3,41	3,9	4,42	4,97	5,54

notes:
ENCD

DIN ISO 13920 Tolerances B

revisions-no. A1 mm / kg

date	name
drawn by 25.10.19	JMA
checked by 25.10.19	SWA
approved by 25.10.19	JWY
modified by	



description Elbow 15°

code 215-DWECO16

drawing-no. 01-02-35-6001-205

scale 1:3

format A4

sheet 1 of 1

