

A

B

C

D

E

F

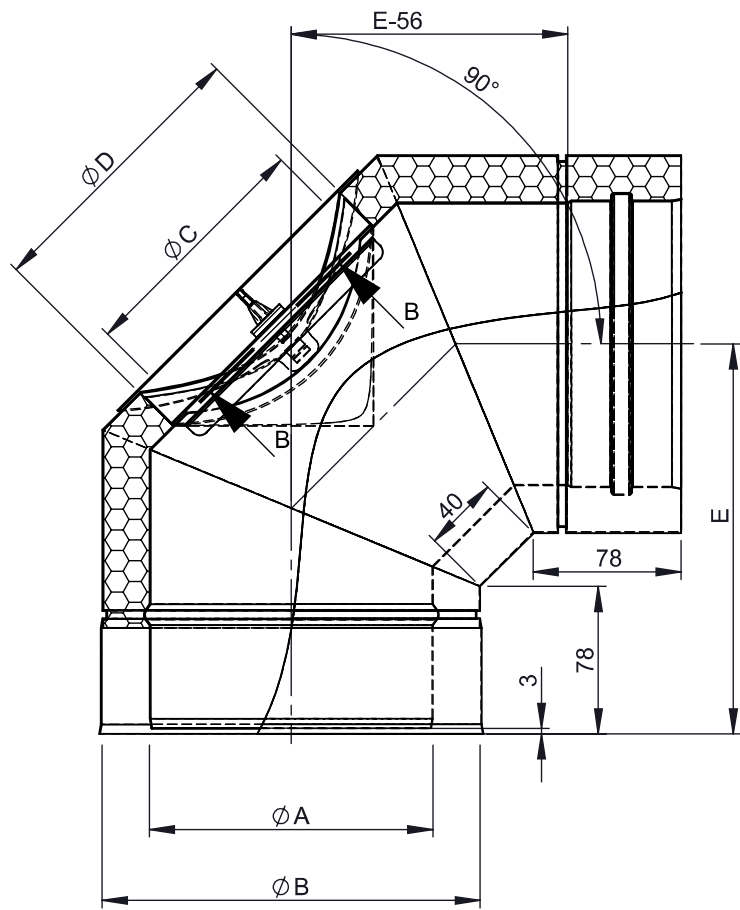

↓
P < 0 Pa

600°C

Water drop icon

Ö, G, F

25 mm

SCHNITT B-B
MAßSTAB 1 : 4

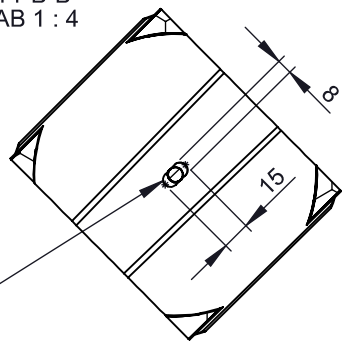

LL im Revisions-Innendeckel

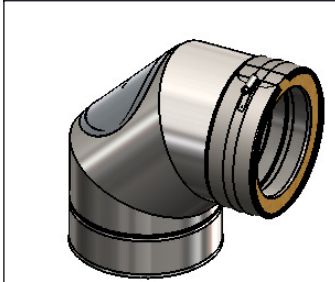

1:10

Ø	080	100	115	120	130	140	150	160	180	200	250	300	350	400	450	500	550	600
A	80	100	115	120	130	140	150	160	180	200	250	300	350	400	450	500	550	600
B	130	150	165	170	180	190	200	210	230	250	300	350	400	450	500	550	600	650
C	60	70	80		100			130					180		200			250
D	80	100	115	120	130			150		180		250			300			350
E	173	183	191	193	198	203	208	213	223	233	258	283	308	333	358	383	408	458
t/t _a	0,5 / 0,5																	
kg	1,1	1,4	1,7	1,7	2,0	2,0	2,3	2,4	2,8	3,2	4,3	5,4	6,8	8,3	9,9	11,6	13,6	15,6

material: inside/outside		surface: inside/outside		revisions-no.		date		name		description		Scale	
444/304		3C/3D		A2		01.06.2011		FST		DWETN 19 Reinigungswinkel 90° (bis 600°C)		1:5	
										code		Format	
										DWETN 19		A4	
										drawing-no.		Sheet	
A2		19.10.2015		JGR		appr.						1	
revision		date		name									

All rights reserved!