

$\text{ØC} \leq 400$ Deckel ist gepresst

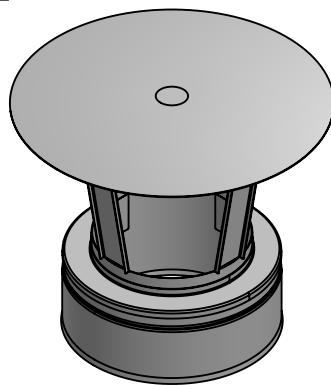

$400 < \text{ØC} \leq 600$ Deckel ist flach

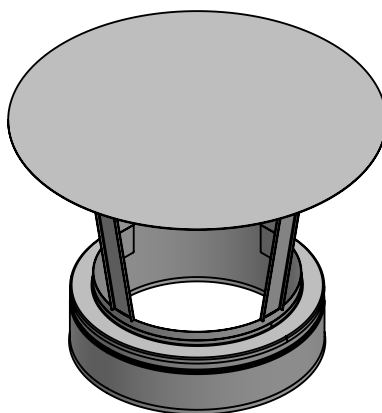

$\text{ØC} > 600$ Deckel ist gekantet

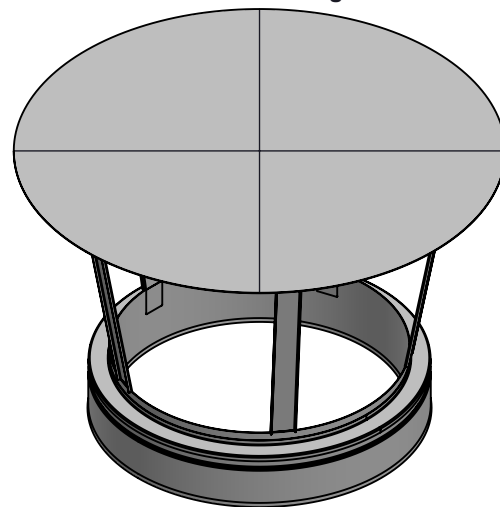

Ø	80	100	115	120	130	150	160	180	200	225	250	300	350	400	450	500	550	600
A	78	98	113	118	128	149	158	178	198	223	248	298	348	398	448	498	548	598
B	130	150	165	170	180	200	210	230	250	275	300	350	400	450	500	550	600	650
C	280					300			330	360	450	510	600	650	700	760	810	950
D	145								185	190	220	270	315		380	400		430
E	245								285	290	320	370	415		480	500		530
n	4											5		6		8		
kg	1,2	1,3	1,4	1,4	1,4	1,5	1,6	1,7	2,0	2,3	2,8	3,7	4,7	5,3	6,2	6,9	7,9	9,5

notes:

DIN ISO 13920 Tolerances B

revisions-no.

A1

mm / kg

date

29.04.2021

name

KSA

checked by

approved by

modified by

description

Jeremias
CHIMNEY SYSTEMS

Mündungsabschluss mit Regenhaube

code

215-DWECO1076

drawing-no.

01-02-35-5102-215

scale

1:3

format

A4

sheet

1 of 1

